

12 Volt Timer w 2 Circuit Relay Color Coding

Timer

Purchased at Amazon

Can be set to run from 1 second to up to 1 hour (60 Minutes)

Optimum operation is 12 Volts DC

See Info—all 12 volt timer sheet

















I have used the timers in the past wired as shown with the mini relay removed and replaced by two diodes.

I needed to show also how to wire the timers un-changed from the factory.

There are 2 diagrams showing both ways to wire the timer itself.



Activation Plug - JST 2 Pin Male Female Connector

12 Volt DC Positive Impute.....	 	12 Volt DC Positive to Timer and Relay
12 Volt DC Negative Impute.....	 	12 Volt DC Negative to timer, Relay
Button Timer Activation.....	 	Button Timer Activation to Timer
Button Timer Activation.....	 	Button Timer Activation to Timer
Button Light Positive.....	 	Button Light Positive from the Relay
Button Light Negative.....	 	Button Light Negative from the impute
Hot wire from the power source.....	 	Hot wire to the relay
Hot Wire to the item to operate.....	 	Hot Wire from the relay

Timer Wiring Choices

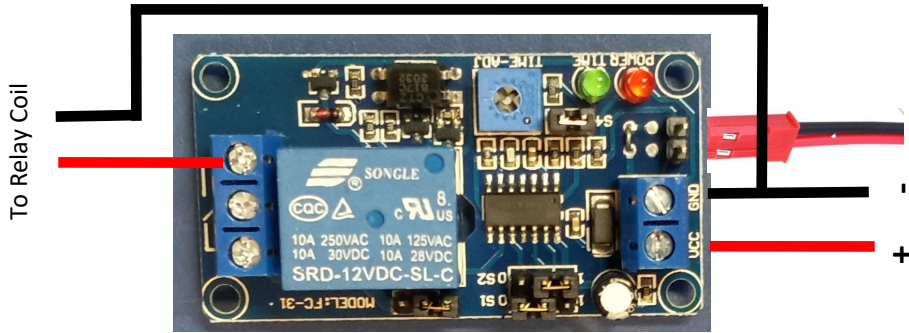

This is the original Timer purchased as of today and it looks the same.

This timer is wired to activate a 12 Volt DC Relay by activating the timer's attached relay. The timer/relay is a one circuit relay as purchased and can use the same power source to use the



Activation Plug - JST 2 Pin Male Female Connector

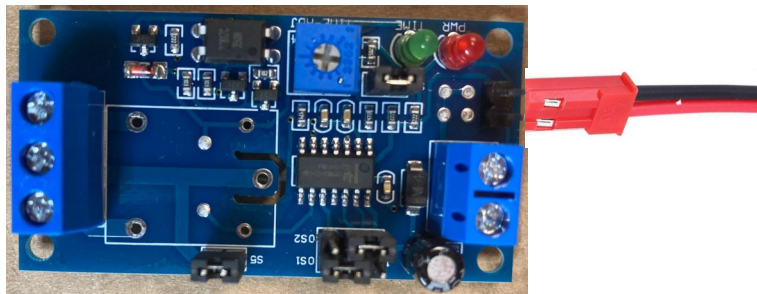

This timer is shown with the Relay removed. I have used these timers after removing the relays mostly because some of the attached relays have failed. The timers seem to work

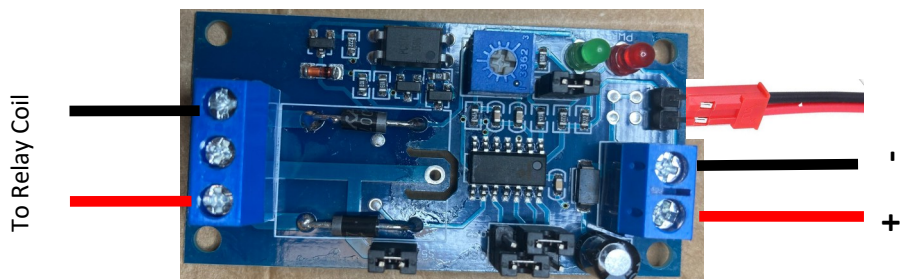

This timer is shown with two diodes replacing the relay.

After I removed the attached relay I then soldered in two diodes across the solder points of the relay. This allows me to wire directly through the timer to activate another relay.

Basic 12 Volt Timer w 2 Circuit Relay w/Factory Timer

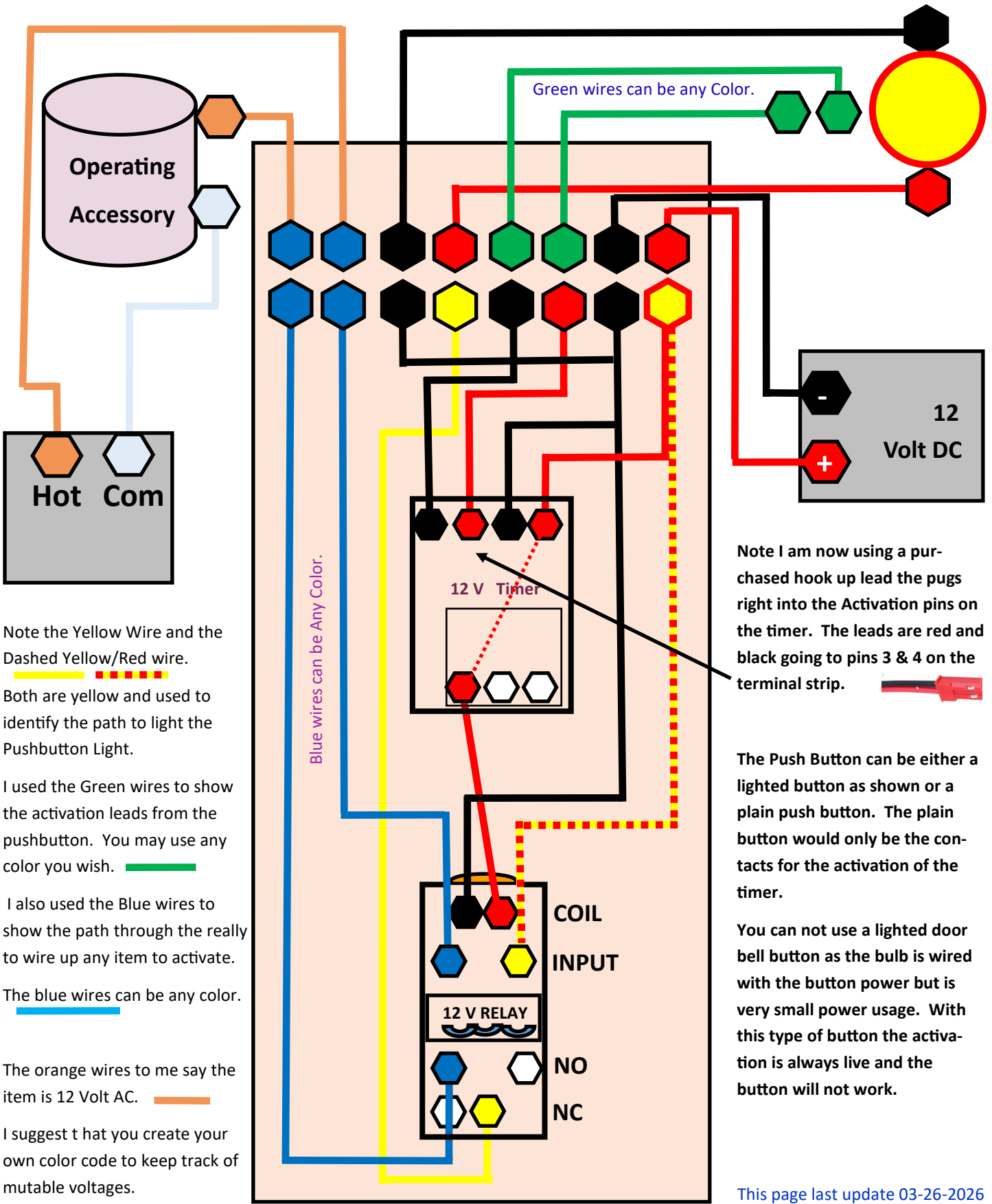

Note the Yellow Wire and the Dashed Yellow/Red wire. — —
 Both are yellow and used to identify the path to light the Pushbutton Light.

I used the Green wires to show the activation leads from the pushbutton. You may use any color you wish. —

I also used the Blue wires to show the path through the really to wire up any item to activate. —

The blue wires can be any color. —

The orange wires to me say the item is 12 Volt AC. —

I suggest t hat you create your own color code to keep track of mutable voltages.

Note I am now using a purchased hook up lead the pugs right into the Activation pins on the timer. The leads are red and black going to pins 3 & 4 on the terminal strip.

The Push Button can be either a lighted button as shown or a plain push button. The plain button would only be the contacts for the activation of the timer.

You can not use a lighted door bell button as the bulb is wired with the button power but is very small power usage. With this type of button the activation is always live and the button will not work.

Chart to set the Timer's Length of Time

12 Volt DC Power supplies both the timer and the item timed to work with an internal connection.

S1		1 Second to 15 Seconds
S2		
S1		1 Second to 60 Seconds
S2		
S1		1 Minute to 8 Minutes
S2		
S1		6 Minutes to 60 Minutes
S2		

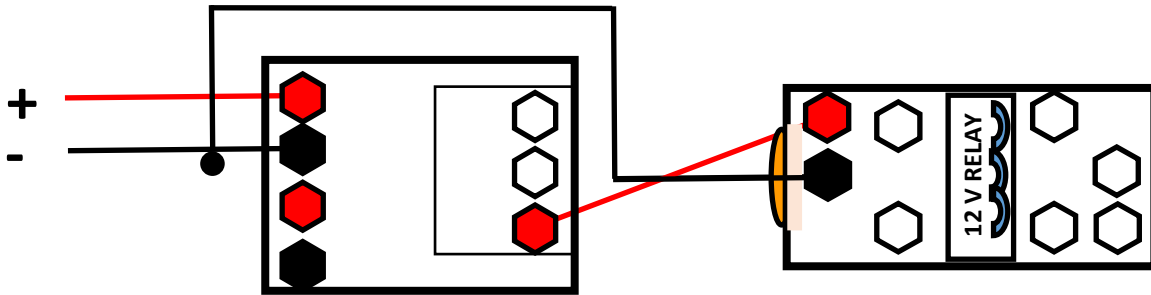

**S5 leave attached to run the relay
From the timer power 12 V DC**

S1 = Switch 1
S2 = Switch 2
NC = Normally Closed
NO = Normally Open
+ = Positive DC
- = Negative DC

Activation Plug - JST 2 Pin
Male Female Connector

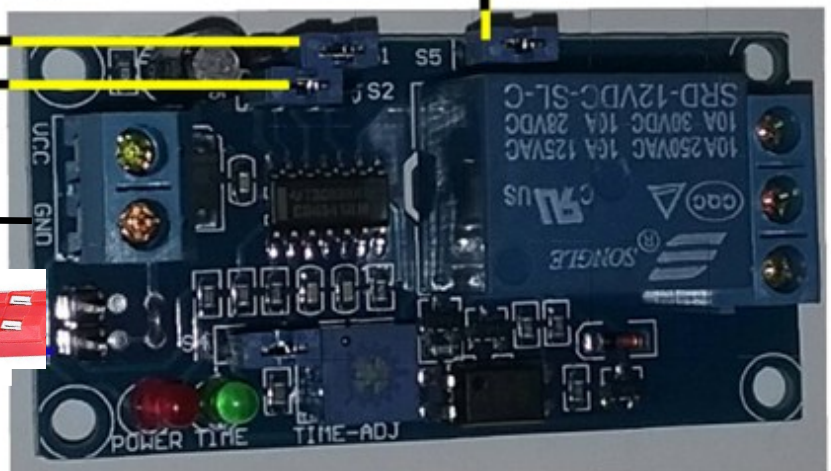

PDF-12 Volt Timer diagram



Activation Plug - JST 2 Pin Male Female Connector

All - Timer - 12 Volt Timer Diagram with 2 Position - 12 V Relay.pub

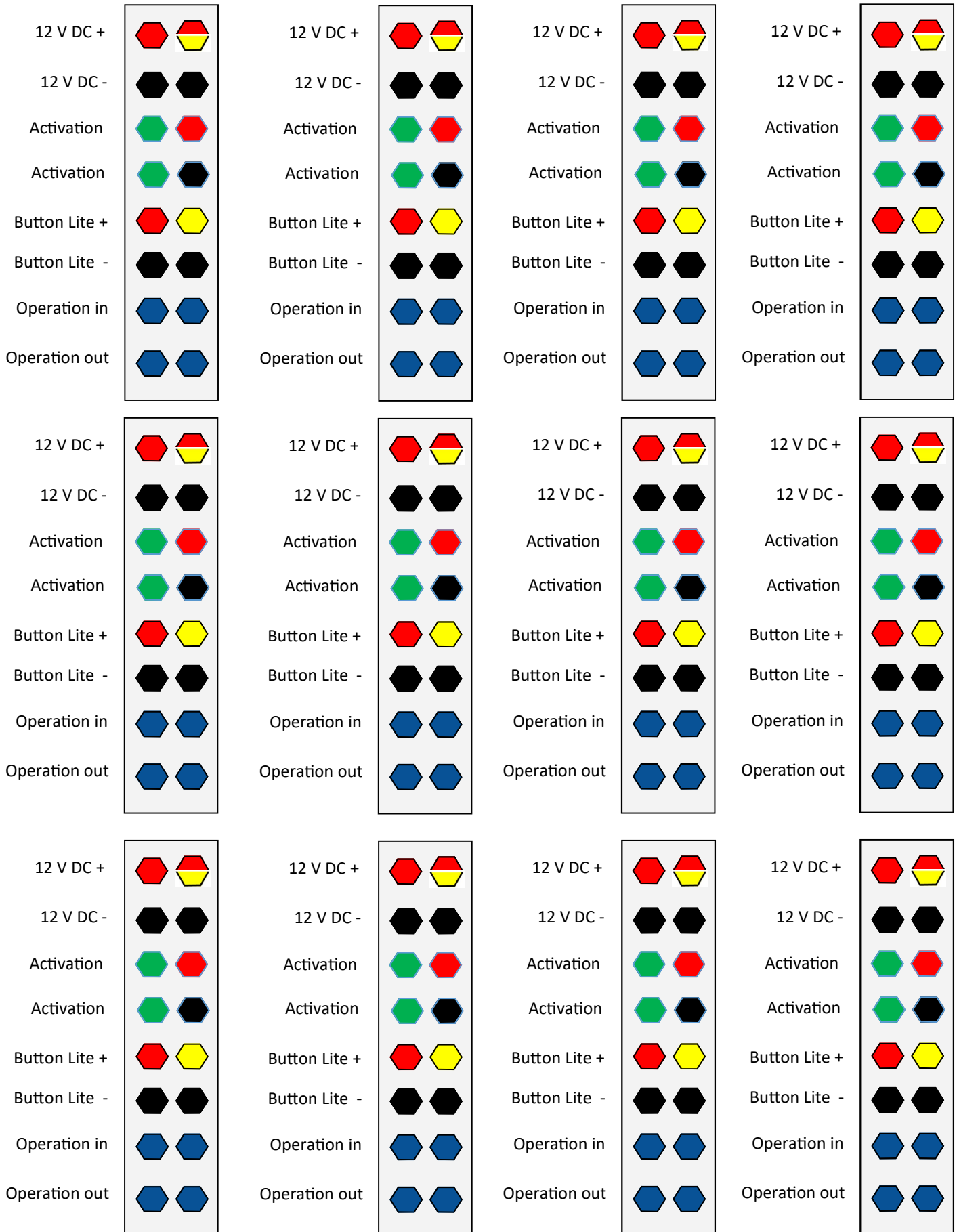

These are guides that I use for teaching a class to build a simple timer.