

Simple Relay Wiring

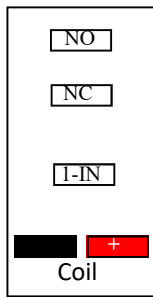

1 CIRCUIT

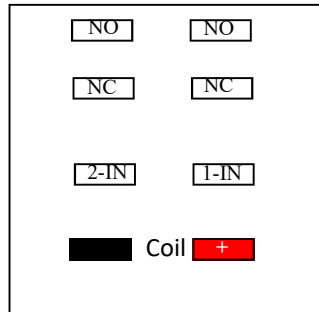

2 CIRCUITS

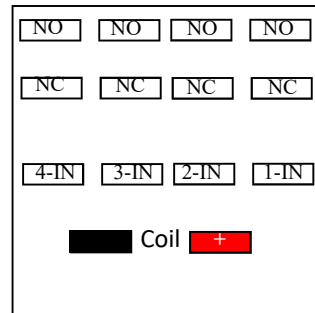

4 CIRCUIT

Above are 3 Relay Cubes looking at pins on the bottom.

There are most common 3 cubes: 1 circuit, 2 circuits and 4 circuits.

I like to use 12 V DC for the coil to operate the relay itself.

There are many others that use from 6 Volts to 110 Volts AC and DC varieties.

We are only going to deal with 12 V DC and the same is applied to any of them.

When the Cube is at rest with no electric to fire the coil is how they work.

Power going into the IN (From Power Source) pin and will be hot on the NC (Normally Closed) pin and the NO (Normally Open) pin will not have any electric going through it.

When you apply power to the Relay Cube you will cause the electric to stop flowing through the NC pin and then the NO Pin will be activated.

I will give you the simple wiring for this to use with a Lighted or Unlighted Button to activate the Relay. I will use the 2 circuit cube for my Diagrams.

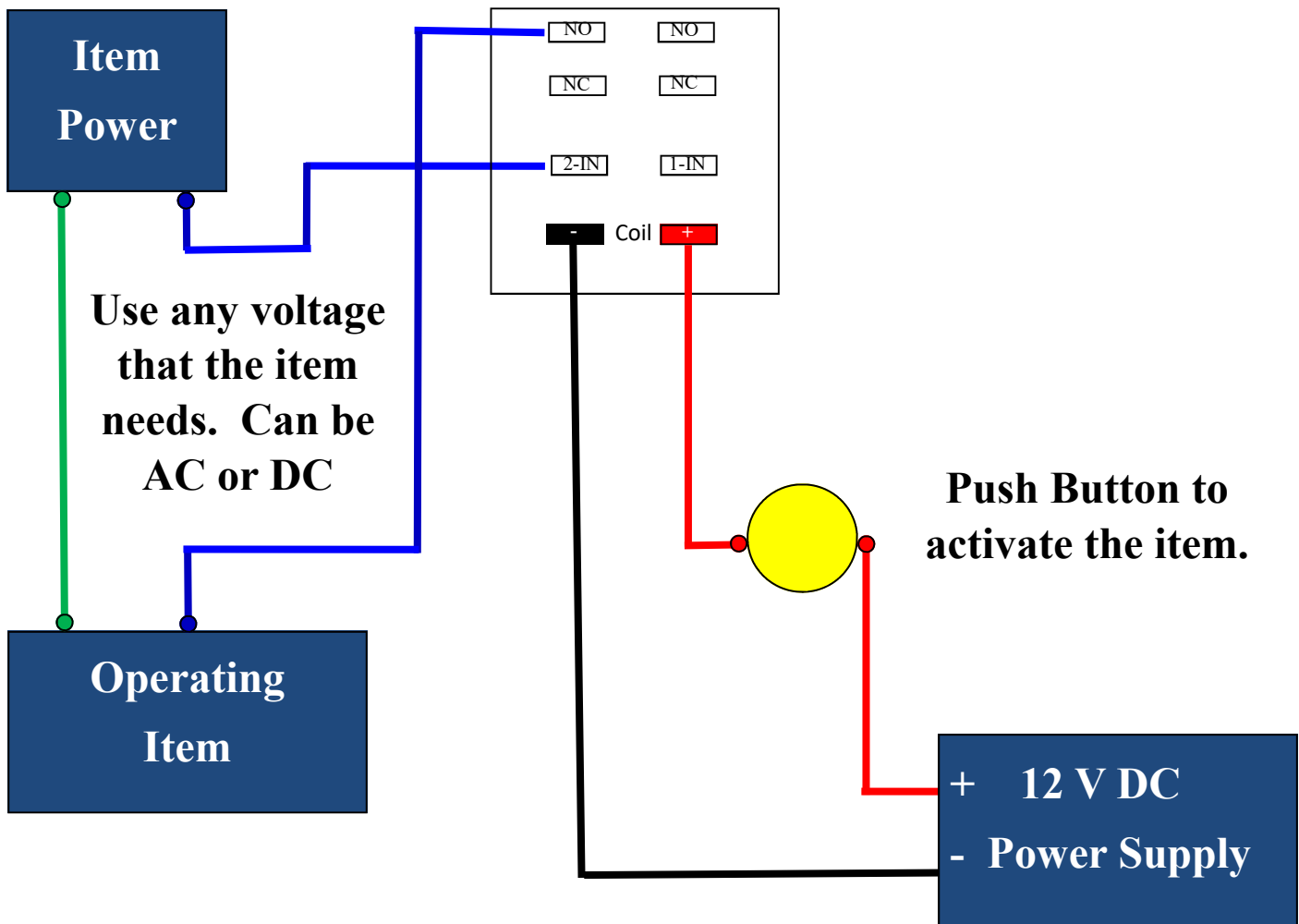

In this diagram when you push the Button then the Item will operate. When the button is released the item will stop running.

You can also use a toggle switch or a slide switch to turn on and off.

Truthfully in this manner the Relay is not needed at all. As soon as you get into timers and mutable circuits then the Relay will come into play and you will then have a working idea of how to use it.

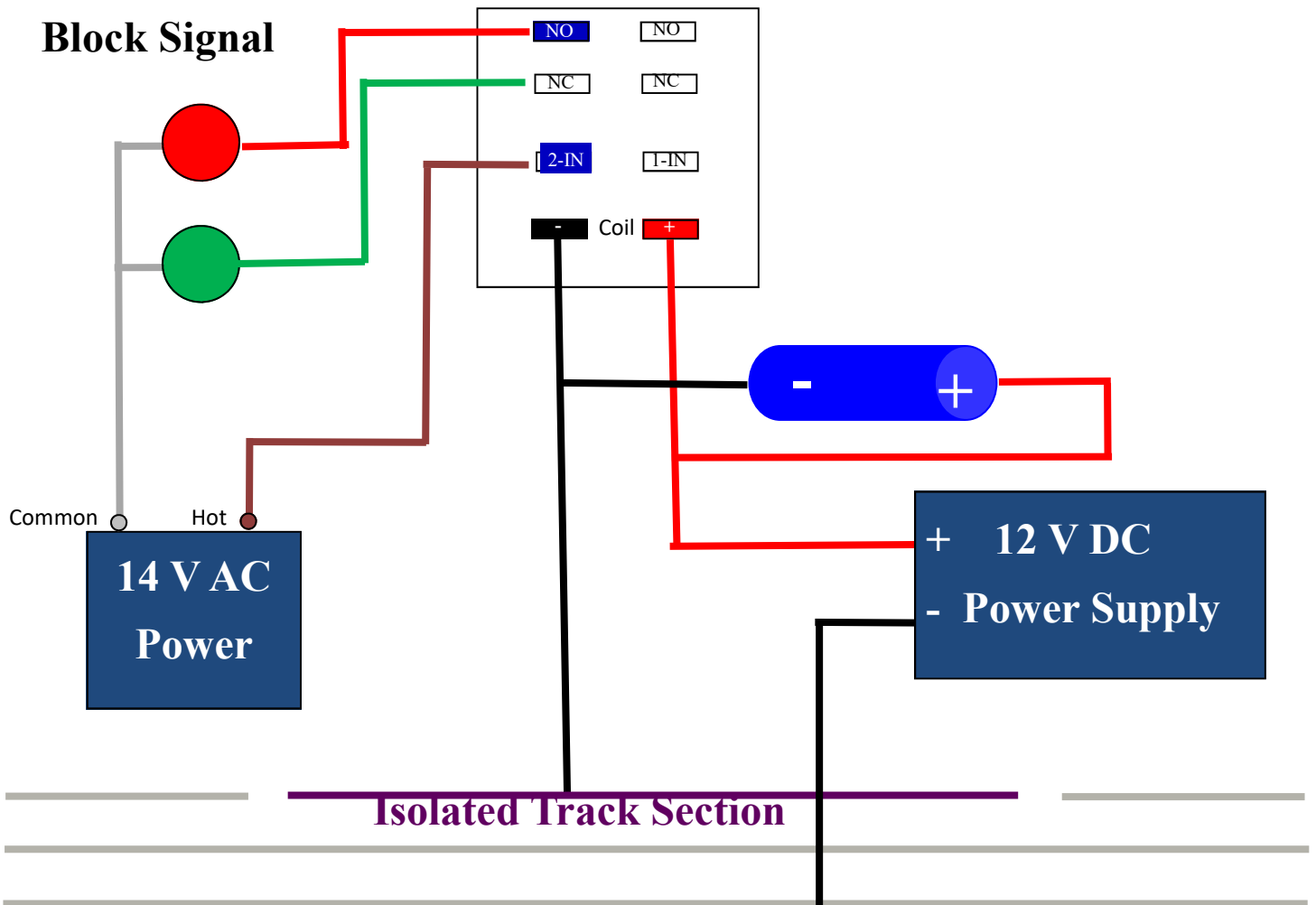

Using an isolated section of track to activate the Relay and change the color of the Block Signal Bulbs from Green to Red.

You will attach the DC Negative Power to the normal outer AC track. DC negative will flow through the same common wiring for AC with no interruption of electrical action. When the wheels of the train occupy the section of track that is isolated then it closes the circuit to activate the Relay.

Before the Train occupies the isolated section of track the Green Light is powered and lit. As soon as the wheels cross then the light will change from Green to Red.

I have also attached a Capacitor to the wires that activate the Relay. With the capacitor included this will keep some of the chatter down from the wheels not maintain solid contact. The capacitor actually holds a small charge of the DC power and will release it when the power is not to the capacitor.

Socket Wiring diagrams 8 and 14 pin Relays

Looking at the Bottom of a 14 Pin cube

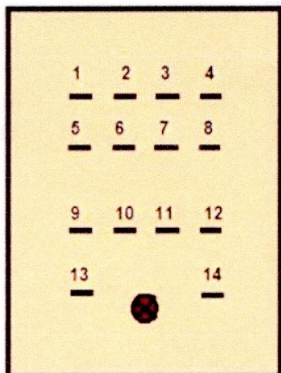

Cub Relay and Base

The drawings here represent the cube relays. They show the pin numbers shown on the bottom of the relays and the bases are the other drawings.

Please note that there are a number of bases and the pin number do not always come out the same.

You may need to check the circuits with a meter to be sure that you have the correct NO and NC pins to work your relay.

Looking at the Bottom of a 8 Pin cube

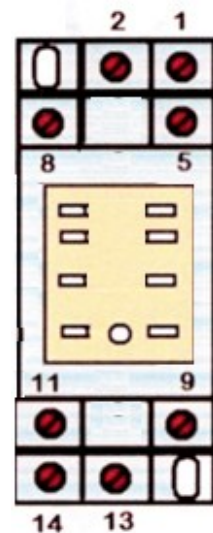
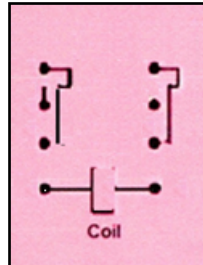
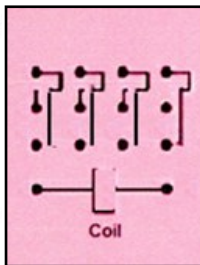
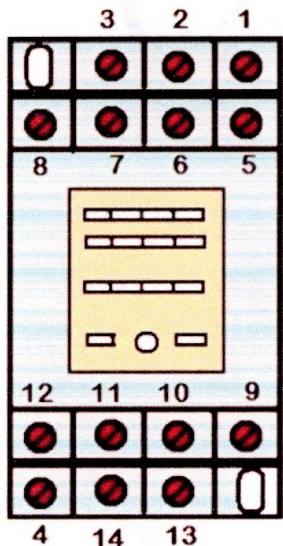
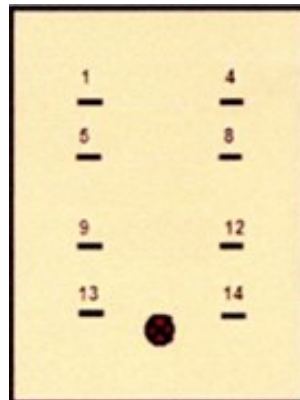

Diagram as used for 14 pin relay

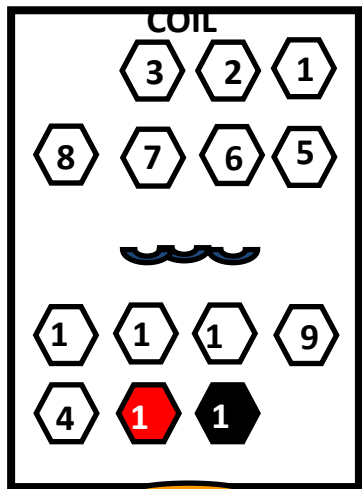

Diagram as used for 8 pin relay

