

Compact Circuit Board Flasher to Flash Crossing Signals Alternately

This unit will allow you to work 2 LED lights that will flash alternatingly.

You must have at least 2 lights hooked up as the flasher will not work using only one light.



I have discovered if you are using a postwar Lionel 154 signal and if you replace the 2 incandescent bulbs with red LED bulbs that are designed to work on AC or DC then you can wire direct to the 3 posts in the following manner.

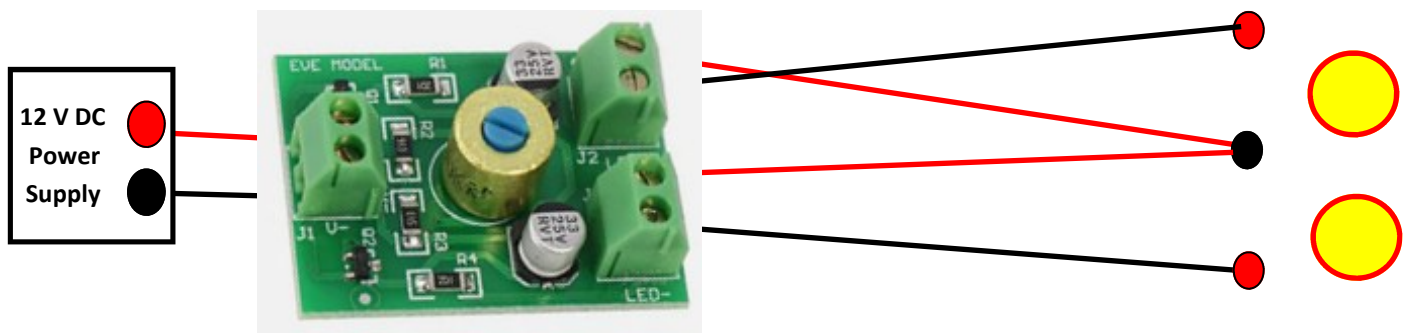

Wire both positive connections from the flasher to the lights common post. Then wire each negative wire to one of the light hot post. This seems backwards but the bulb being allowed to run on AC allowed the leads to be reversed and it works.

LED Flasher Wired with Timer - Relay and Push Button

Using a Factory Timer

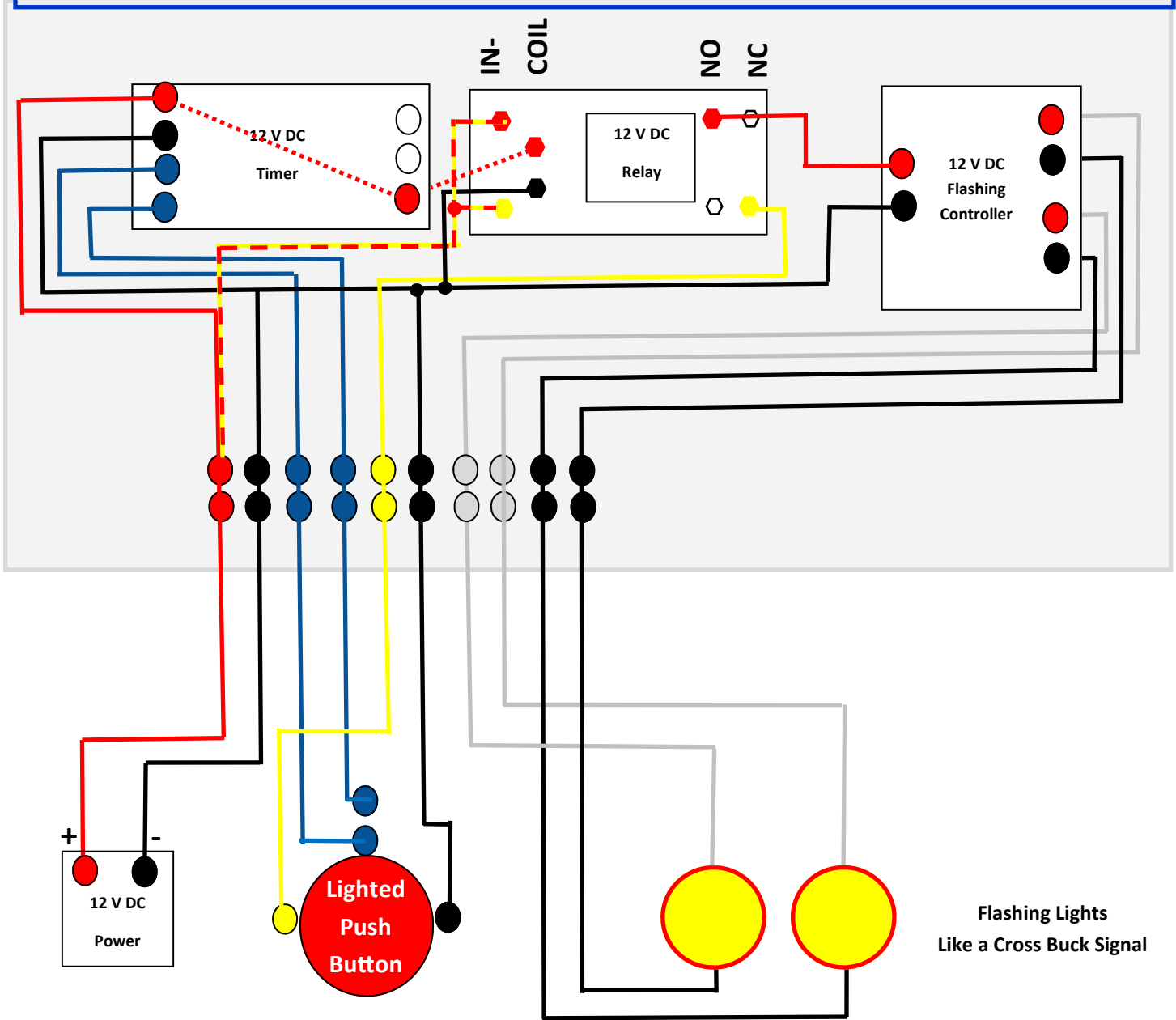

This is the standard drawing that allows you to operate a pair of flashing LEDs such as a cross buck by pushing a button. Note the dashed Yellow and Red wire going to the relay is from the 12 V input to operate the lighted push button and to power the flashing unit.

LED Flasher Wired with Timer - Relay and Push Button

Using a Revised Timer

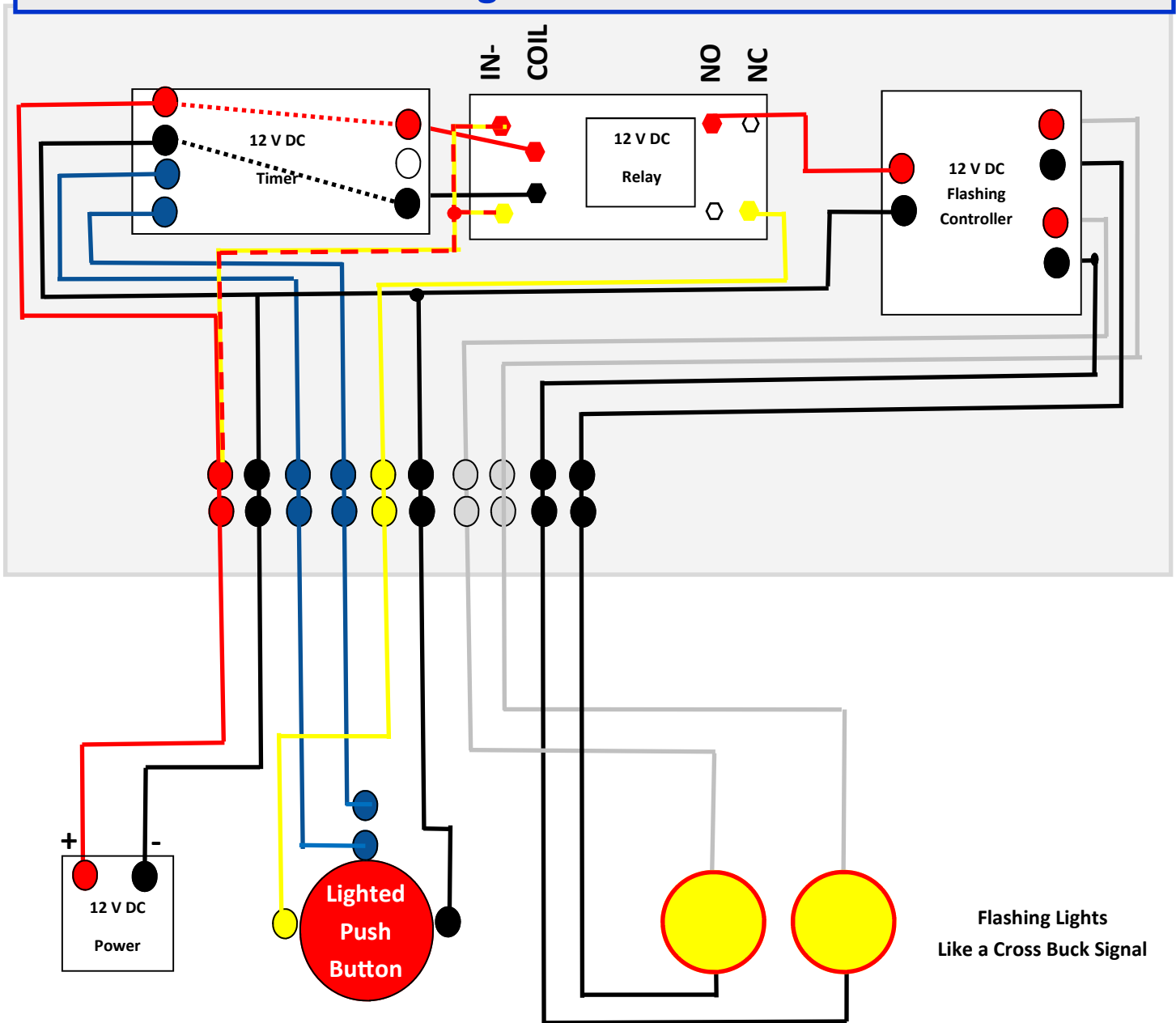

This is the standard drawing that allows you to operate a pair of flashing LEDs such as a cross buck by pushing a button. Note the dashed Yellow and Red wire going to the relay is from the 12 V input to operate the lighted push button and to power the flashing unit.

Timer Wiring Choices

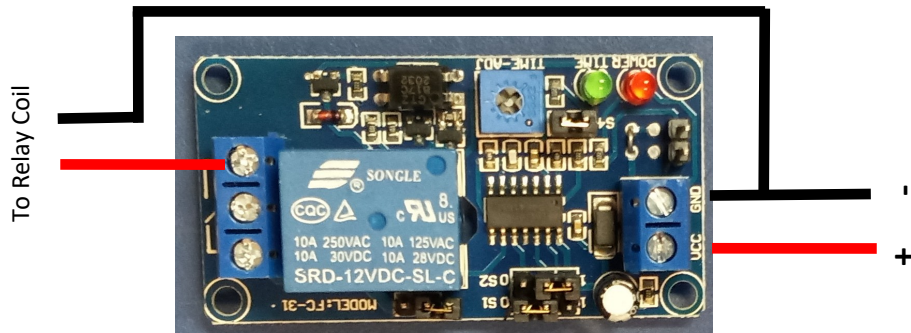

This is the original Timer purchased as of today and it looks the same.

This timer is wired to activate a 12 Volt DC Relay by activating the timer's attached relay. The timer/relay is a one circuit relay as purchased and can use the same power source to use the

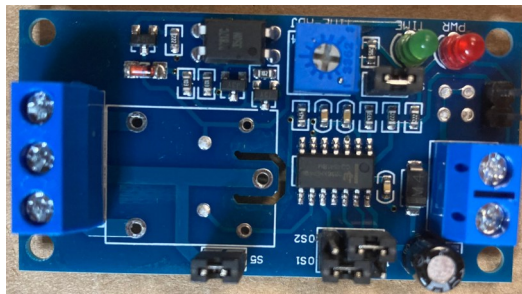

This timer is shown with the Relay removed. I have used these timers after removing the relays mostly because some of the attached relays have failed. The timers seem to work

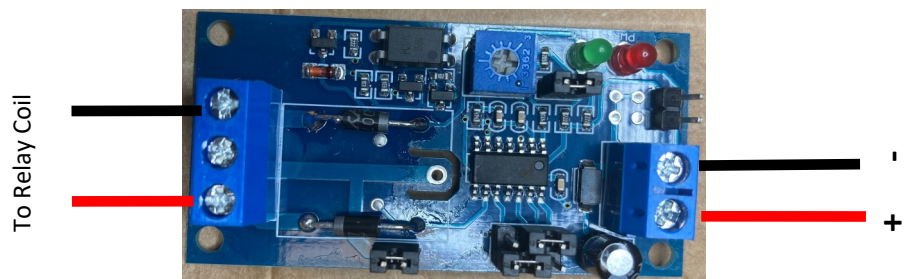



This timer is shown with two diodes replacing the relay.

After I removed the attached relay I then soldered in two diodes across the solder points of the relay. This allows me to wire directly through the timer to activate another relay.

Time Settings for the timers

12 Volt DC Power supplies both the timer and the item timed to work with an internal connection.

- S1   **1 Second to 15 Seconds**
 S2  
- S1   **1 Second to 60 Seconds**
 S2  
- S1   **1 Minute to 8 Minutes**
 S2  
- S1   **6 Minutes to 60 Minutes**
 S2  

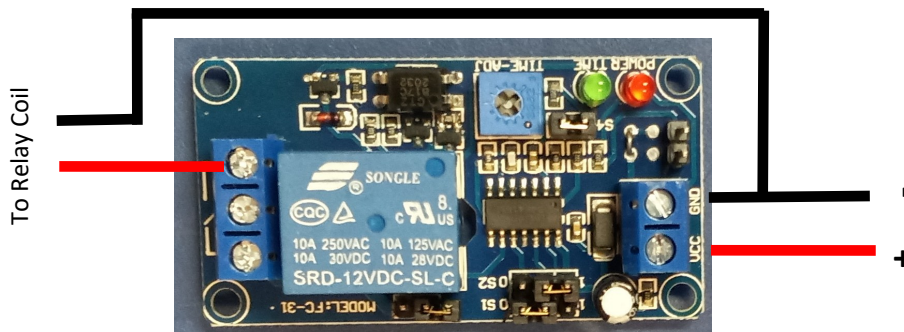

**S5 leave attached to run the relay
From the timer power 12 V DC**

- S1 = Switch 1
 S2 = Switch 2
 NC = Normally Closed
 NO = Normally Open
 + = Positive DC
 - = Negative DC

Activation Wire Pin +



PDF-12 Volt Timer diagram