

## LOTS Switcher Article Written July 29-2022

Frank Kammer RM-1767

**This document is how to wire a timer and a relay to operate an item for a specific amount of time from 1 second to up to 1 hour.**

**You will need the following items as diagramed on page 2.**

**12 volt power supply (Transformer)**

**Power supply to operate the Operating item either AC or DC+**

**12 Volt DC Timer**

**12 Volt 2 circuit or 4 circuit relay (I used a 4 Circuit in this document)**

**14 pin relay base for relay (Optional as you can solder the wires Directly to the pins on the Relay. It is just easier to use.**

**Note All bases are not wired the same therefore the diagram Used may be slightly different**

**8 pin (Circuit) terminal bar**

**Operating Item either AC or DC**

**Push Button either lighted or unlighted with second contacts for the light**

**If not a lighted button ignore the Red and Black wire from the button to the 8 pin (Circuit) terminal bar.**

### Operation

**Push the PUSH BUTTON and the timer will be activated.**

**The RELAY will kick in**

**The TIMER will operate for the designated time you set it for.**

**The OPERATING ITEM will run for this amount of time**

**If the Push Button is LIGHTED the light will go out for the length of time set.**

### After the timer expires the

**Relay will go back to Rest**

**The item will quit working**

**The button light will light up again.**

**Note \*\*\* I have this time in use in over 100 applications here in Cincinnati. There are many other timers and anyone that you use should work the same way. I am just documenting what I have used with great success.**



manufactured by **WORLD CHIPS**

**Based in China**

**World Chips has been an eBay member since Dec 11, 2011**

eBay Link as of 18-02-18

<https://www.ebay.com/itm/DC-12V-Delay-Timing-Timer-Relay-Turn-ON-Turn-OFF-Switch-Module-Time-10A/332506888918?hash=item4d6af47ad6:g:ngsAAOSw4PxaTDka>

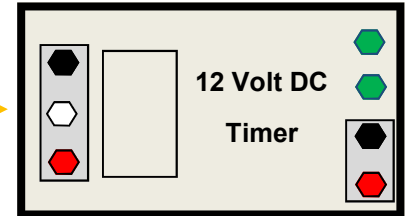
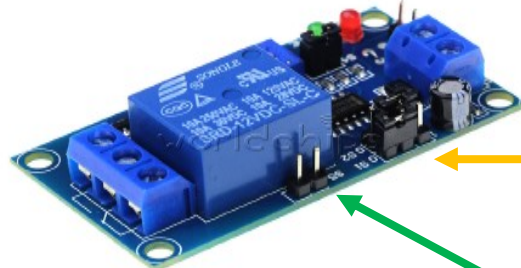

**S5 Jumper shown removed, please keep it on the pins.**

**Below are diagrams used in this file along with the colors for the circuits.**  
**I have used Yellow as a guide for the button light that is 12 V DC**  
**The Green leads from the push button are just another guide, any color is fine.**  
**The Blue leads to operate an item are also just a guide any color is fine.**

**Circuit Color Codes**

- 12 Volt DC Positive for Timer, Relay and LED Button Light**
- 12 Volt DC Negative for Time, Relay and LED Button Light**
- 12 Volt DC Positive for LED Button light**
- 12 Volt DC Negative for LED Button light**
- Push Button Leads to Activate timer**
- Hot or Positive Power to operate the Item that you want to run on a**

**8 Pin Terminal Strip**

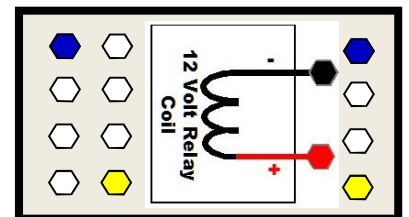
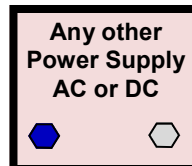
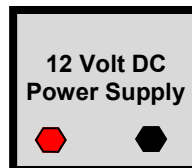
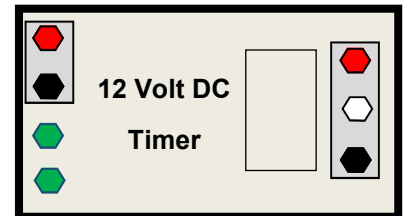
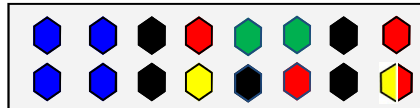
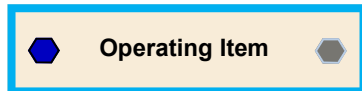

Activation Plug - JST 2 Pin Male Female Connector

# 12 Volt DC Power supplies both the timer and the item timed to work with an internal connection.

---

**S1**   **1 Second to 15 Seconds**  
**S2**  

---

**S1**   **1 Second to 60 Seconds**  
**S2**  

---

**S1**   **1 Minute to 8 Minutes**  
**S2**  

---

**S1**   **6 Minutes to 60 Minutes**  
**S2**  

---

## S5—leave attached to run the relay From the timer power 12 V DC

**S1 = Switch 1**  
**S2 = Switch 2**

**Notes**

**NC = Normally Closed**

**NO = Normally Open**

**+ = Positive DC**

**- = Negative DC**

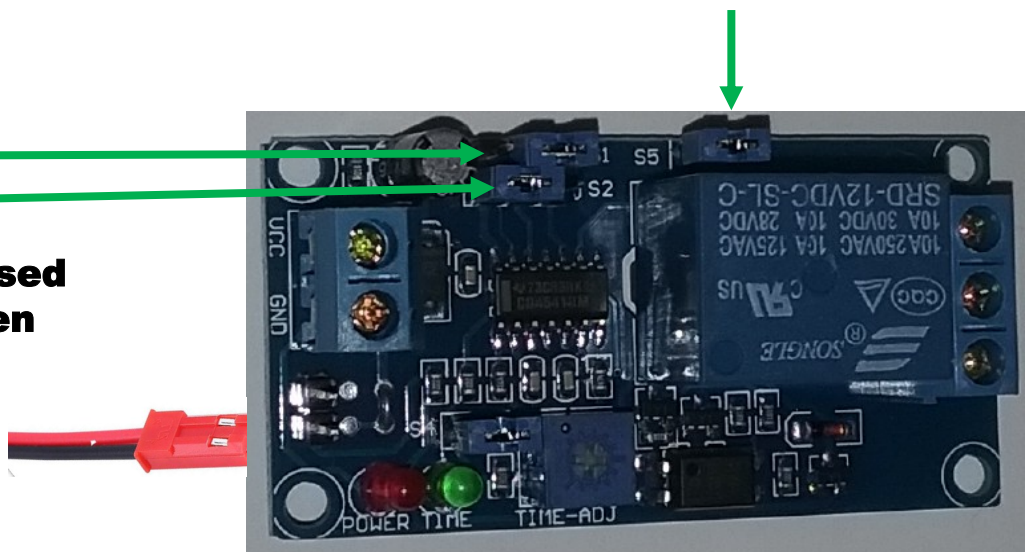

Activation Plug - JST 2 Pin Male Female Connector

# Timer Wiring Choices

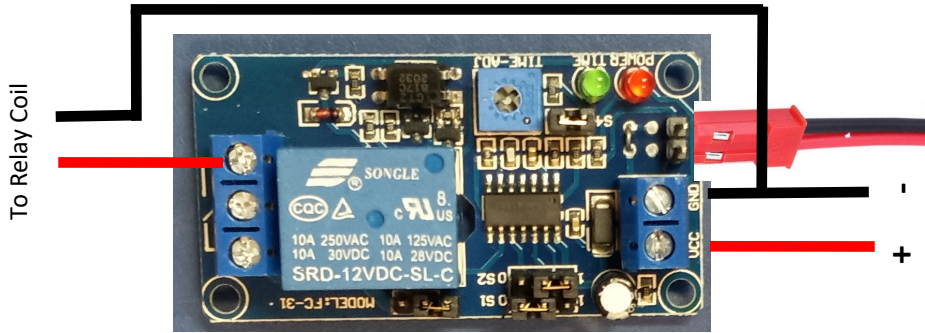

This is the original Timer purchased as of today and it looks the same.

This timer is wired to activate a 12 Volt DC Relay by activating the timer's attached relay. The timer/relay is a one circuit relay as purchased and can use the same power source to use the

When I wrote this article the relays were breaking down on the timer boards. An engineer friend found that the timers still worked and we have had very little problems with the timers. Over the years apparently the Relays on the timer board have been upgraded and we seem to have no problem with the operation of them. I recommend that you use them now straight out of the box wired as above. Frank Kammer LOTS RM-1767 March 24, 2026



Activation Plug - JST 2 Pin Male Female Connector

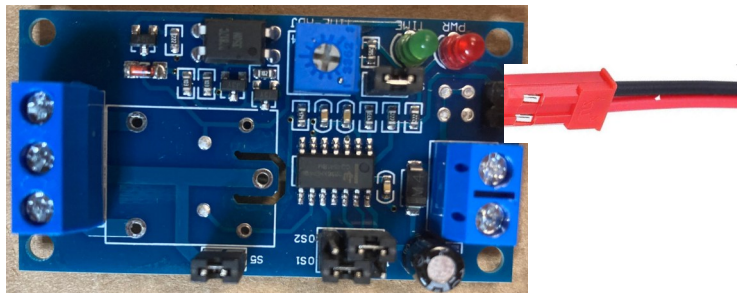

This timer is shown with the Relay removed. I have used these timers after removing the relays mostly because some of the attached relays have failed. The timers seem to work very well overall.

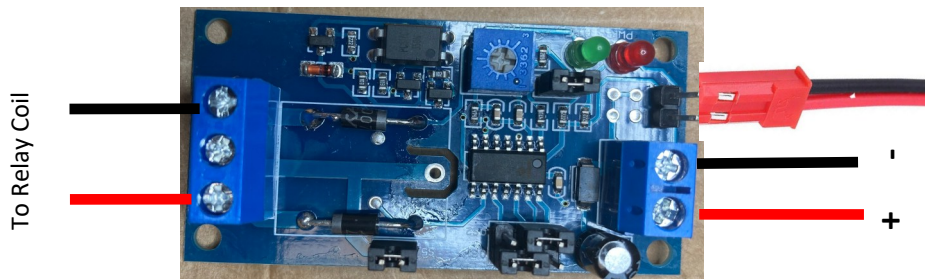

This timer is shown with two diodes replacing the relay.

After I removed the attached relay I then soldered in two diodes across the solder points of the relay. This allows me to wire directly through the timer to activate another relay.

When the timer is activated.

# 12 V Timer Wiring w/Factory Timer

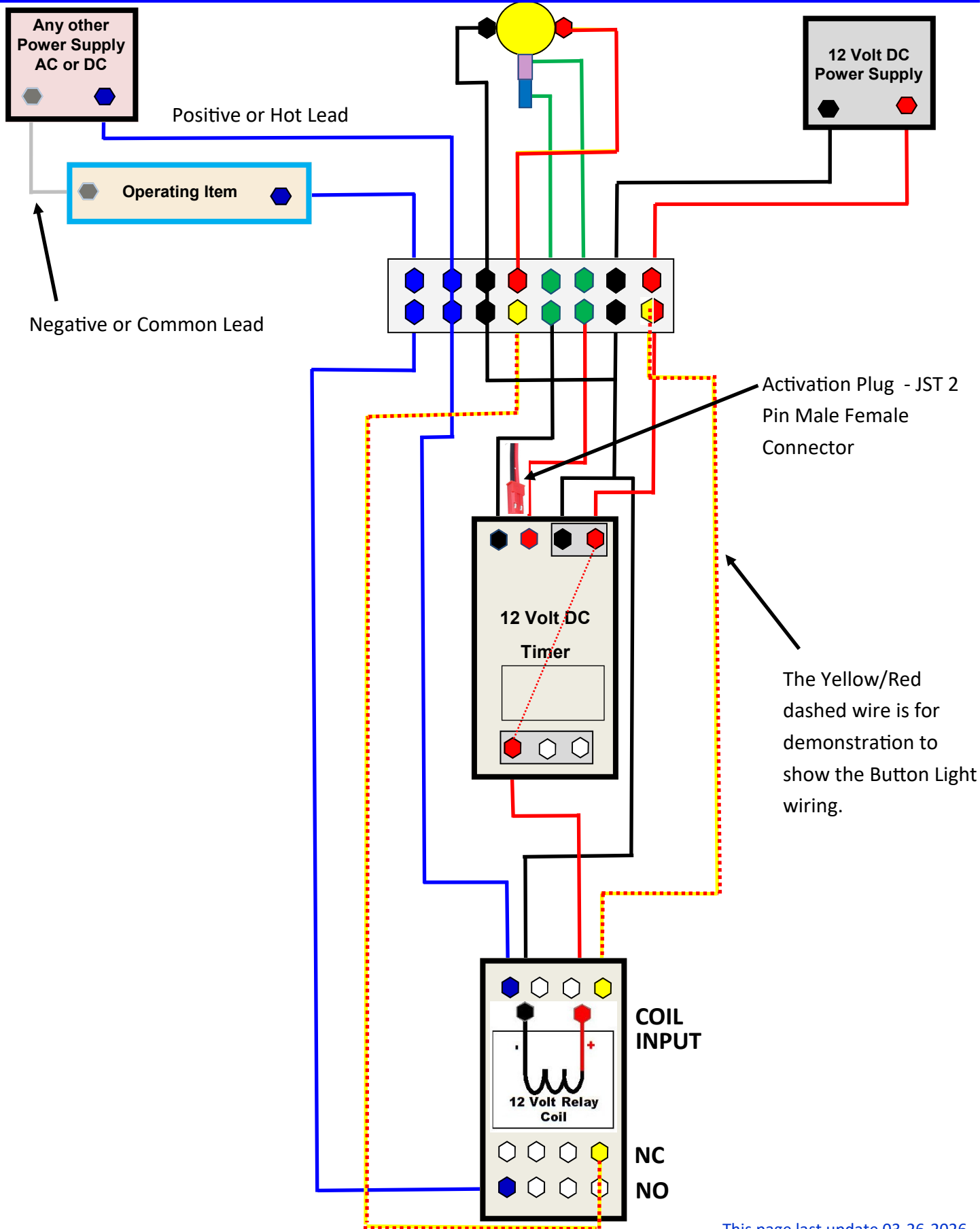

# 12 V Timer Wiring w/Revised Timer

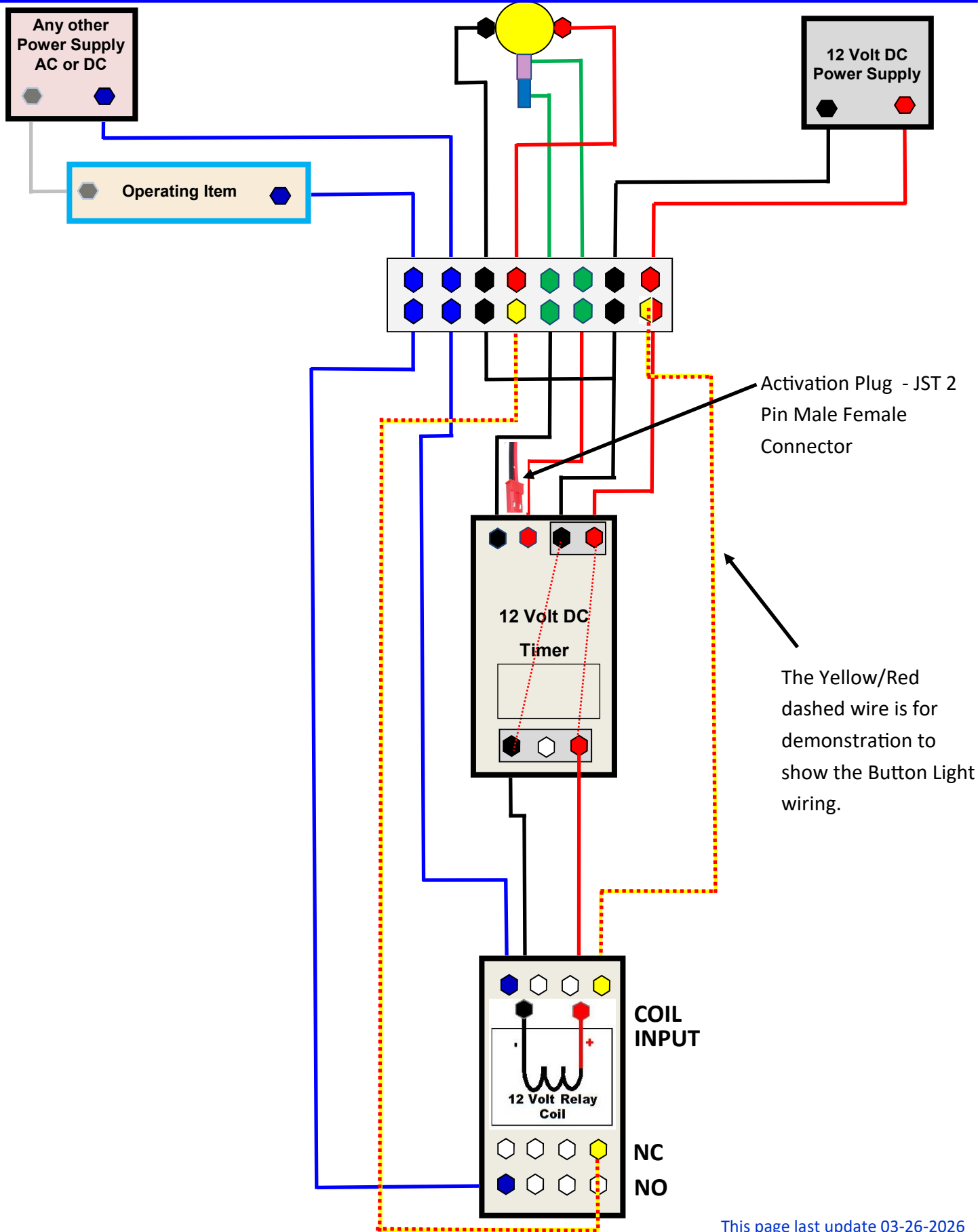

Activation Plug - JST 2 Pin Male Female Connector

The Yellow/Red dashed wire is for demonstration to show the Button Light wiring.

## All - Timer - 12 Volt Timer - LOTS Article.pub

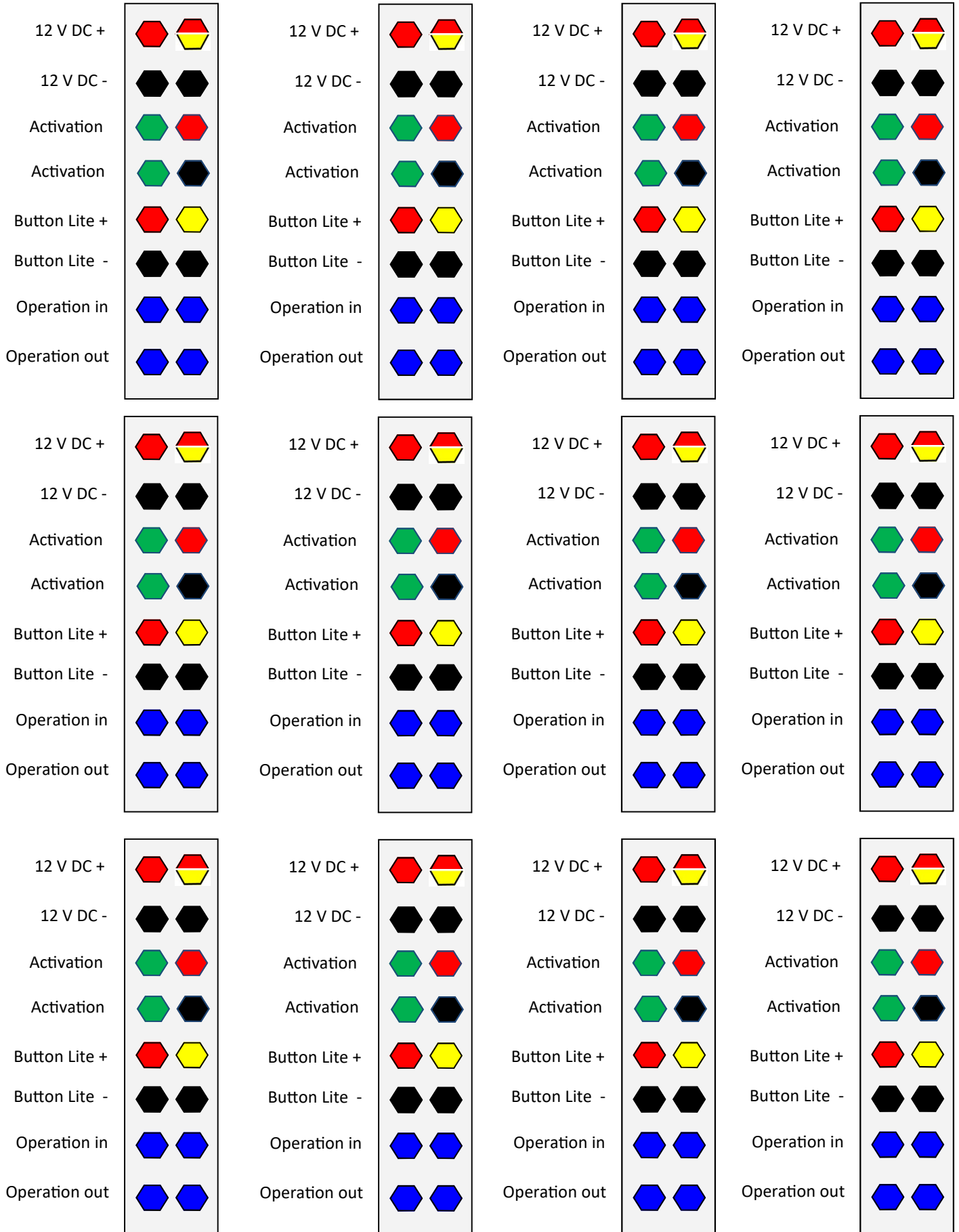

These are guides that I use for teaching a class to build a simple timer.

This page last update 03-26-2026