

## Hamilton City A - City Molex Plugs.pub

I have tried to capture what we discussed and reduced the pages for you to review. I still have included the Pins 10, 11 and 12 Pink, Tan and Green in the 12 pin Molex connectors for possible future use.

We at our meeting on June 1, 2026 decided to wire up all 12 colors and have the wire in place if needed at a future date.

Same on Jumpers to upper boards which are 9 pin Molex Connectors and that would be the pins 7 8 and 9 Pink, Tan and Green wires.

See page 3 for all colors and the assigned pins for the 12 pin and 9 pin Molex connectors

Suggestion to get started.

### Sit down jobs

We have set up so far an LED light wiring crew, a cleaning and PM crew for the rolling stock. Mark the buildings and boxes as they are sitting on the modules with painters tape. L-1, L-2 etc. leaving the original numbers on them. At least we will know what module the building belongs on before looking for its location.

This will not be set in stone until there is rearranging of the building locations. At that time we will further mark the Modules, The Building and the Building boxes with the Module and location of the buildings.

All supplies have been ordered and we will start another crew to start measuring out the cables to the lengths on the map to start wiring up to the Molex Connectors.

The lighting crew will use the wires in the building if possible to attach to the LEDs supplied then attaching Femail .093 pins to the ends of the wires. The wires then be attached to the female Molex connector with the Black or Negative side of the LEDs to the pin hole #2 and the Red or Positive lead in the pin hole #3.

The LEDs are usable in either 12 V AC or DC and our power source is 12 V AC.

### Stand up job

The buss cables will be 3 feet longer that the moduel through the center leaving 18 inches for connection to the next module at both ends.

Fastrack starting all of the Track Power Drops. Take 18 inch drops of the proper color of the hot trach and a white wire for the common our outside tracks. Attach a quick connect 3/16" femail spade connector to both wires for each track using 16 gauge wires of the proper colors. Attache to the male connector then run the two wires throught he wire holders under the track. Then using a hot glue gun put som hot glue so the wirs and not be pulled out easy.

MTH Track you are able to solder to. Fastrack has to be connected under neath by soldering the two drops to the brass connectors using the proper colors for the track and ground.

This should get us started. Until we start wired each module on the under side with the buss and connections to th top of the board for Ttrack and building.

Last Update 26-06-02

# Hamilton City Train Molex Colors



## PINS AND HOUSING CONNECTORS .093

### MALE HOUSING

The housing is hollow and each pin sticks up within the outer wall that will encircle the female housing.

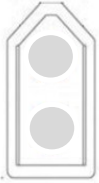

### FEMALE HOUSING

The female pins are inset within the housings to maintain them from being separated when inserting the male pins.



Note this is the way that I started using the housings over 30 years ago.

I suggest we adopt this file for the Hamilton City Train Layout Currently we are only using the 12 pin buss and the 12 V AC for Accessory Lighting.

All AC Common wiring is connected to the common WHITE wire no matter the voltage. The color wires assigned are to be used in the plugs to help identify the voltage by the installer and or the trouble shooter.

The plan at this time is to start purchasing LED bulbs that will work on either AC or DC installation. If attached to AC the leads can be attached in either way. All Hot or Positive should be attached together Wired to the ORANGE lead to the Molex plug. All Common or Negative from the lights should be attached together and wired to the WHITE Molex plug.

If attached to DC power then the positive MUST go to positive RED 12 V DC Buss wire if we use it. Then the negative wires to negative BLACK Buss 12 V DC Wire if we use it.

## 12 Volt AC Male Housing



Currently this is the only Molex Accessory voltage listed on the layout. Note the Male Molex is mounted to the module and the Female is on the building leads.  
White AC Common  
Orange AC Hot

# Hamilton City Train Molex Colors

## Buss Wiring Pin Number and Colors

This list Matches the current tracks

### Upper and Lower Level

Buss is complete around the modules on the lower level, (Full Circle). All upper level modules will be connected directly to the lower level buss. No second buss on the upper level because there will never be a need to set up those 4 modules alone for any operation. All Buss wires are 14 Gauge including the 4 leads from the Buss to the Male connector going to the upper modules. Only exception is for the 12 V DC Pos and Neg which is 16 Gauge, in a sheath.

- Pin 1 = White - Common AC Ground
- Pin 2 = Blue - Track 1 Upper Level Trolley
- Pin 3 = Black - Track 2 Upper Level Inside
- Pin 4 = Red - Track 3 Upper Level Outside
- Pin 5 = Yellow - Track 4 Lower Level Trolley
- Pin 6 = Brown - Track 5 Lower Level Inside
- Pin 7 = Gray - Track 6 Lower Level Outside
- Pin 8 = Orange - Accessory 12 or 14 V AC #1
- Pin 9 = Purple - Accessory 12 or 14 V AC #2
- Pin 10 = Pink - Not In Use at this time
- Pin 11 = Tan - Not In Use at this time
- Pin 12 = Green - Not In Use at this time



Male  
Molex  
Plug



Female  
Molex  
Plug

## Pin Number and Colors

This list Matches the current tracks

### Upper Level

All connection are by cable from each upper module to the Buss on the lower level. All Buss wires are 14 Gauge except for the 12 V DC Pos and Neg which is 16 Gauge.

- Pin 1 = White - Common AC Ground
- Pin 2 = Blue - Track 1 Upper Level Trolley
- Pin 3 = Black - Track 2 Upper Level Inside
- Pin 4 = Red - Track 3 Upper Level Outside
- Pin 5 = Orange - Accessory 12 or 14 V AC #1
- Pin 6 = Purple - Accessory 12 or 14 V AC #2
- Pin 7 = Pink - Not In Use at this time
- Pin 8 = Tan - Not In Use at this time
- Pin 9 = Green - Not In Use at this time

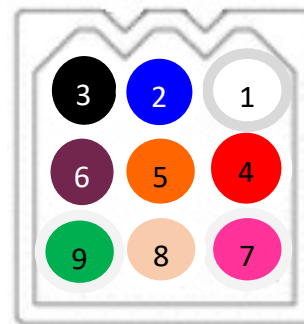

Male  
Molex  
Plug

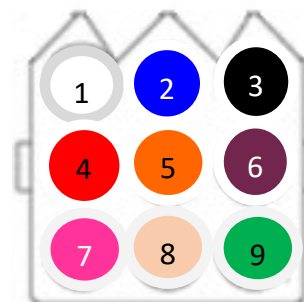

Female  
Molex  
Plug

This is a drawing of suggested renumbering of the modules

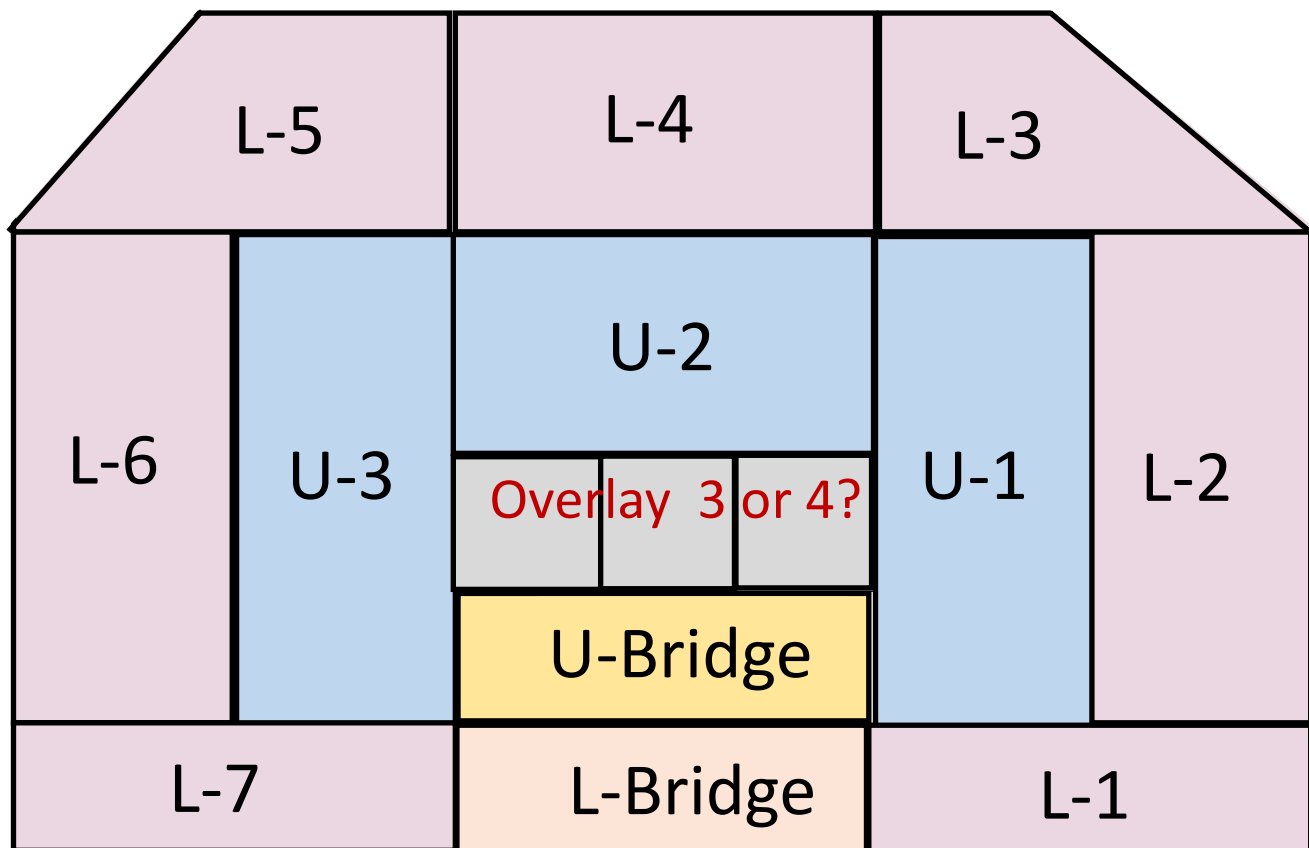

Original  
location  
transformer

### This drawing is a suggestion on numbering the modules

The Transformer was originally set up in the corner as shown.

I started in that corner with L-1 (Lower Level 1) numbering Counter Clockwise with the Bridge Marked Lower Bridge.

Then the same for the U-1 (Upper Level U-1). (YES you can write UPPER and LOWER.

The Transformer cart can be set up anywhere on the modules by Simply plugging in the 2 leads from the cart to the Molex connectors between any set of lower modules.

I am suggesting to attach the upper level modules with a 9 Pin Female Molex connector. The lower level module will have a jumper cable using only the 9 colors available to the upper module with a Male 9 pin Molex connector attached directly to the buss on the lower module.

This is a drawing Buss wiring for the modules

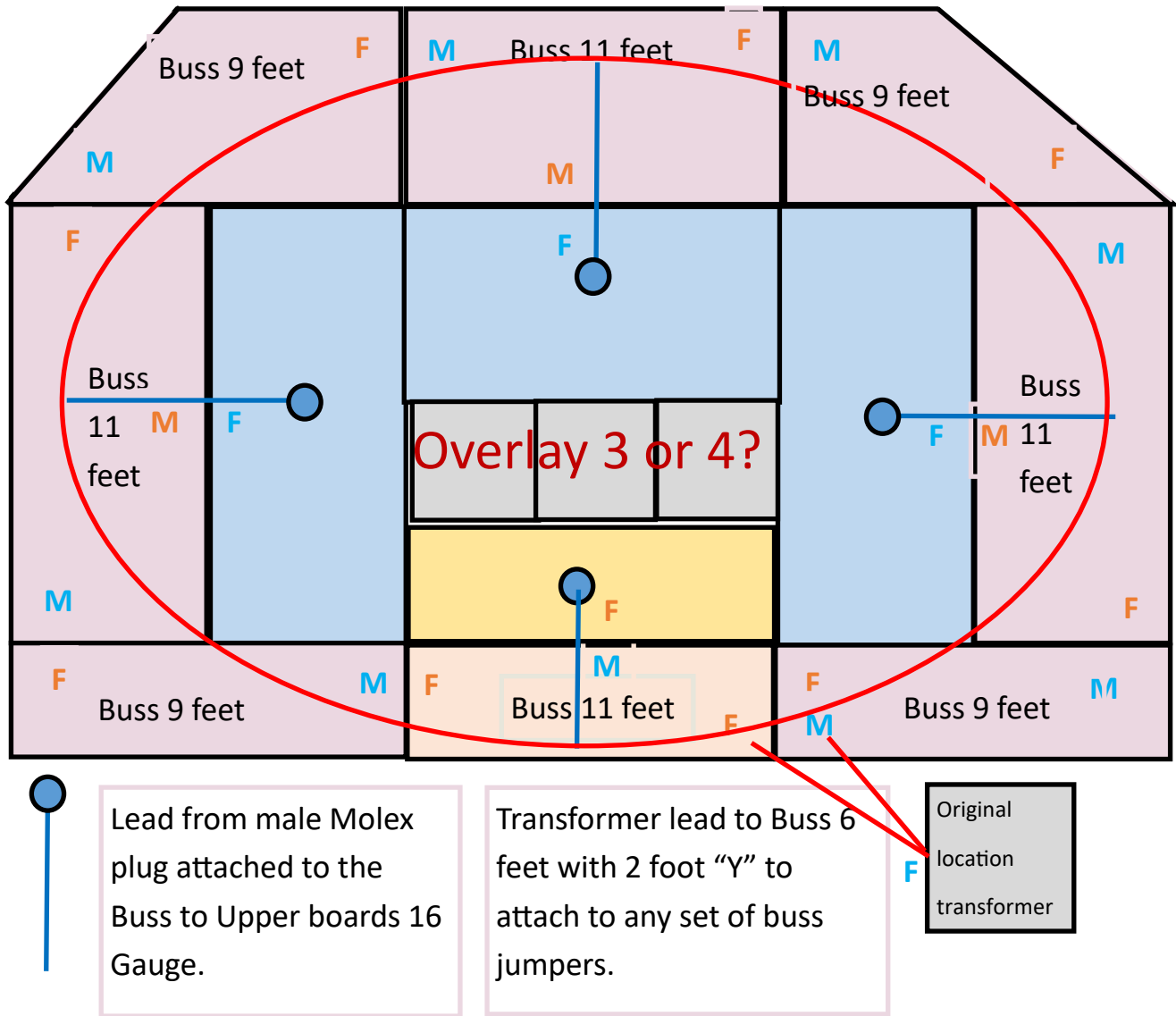

This is a drawing of Suggested wiring of the layout

**LOWER LEVEL**

Red Oval is a buss with all 12 current colored wires 14 gauge with a 9 pin 4 foot lead with a male Molex connector.

Transformer cart attached by a cable to the buss wire. Built to plug into any two connecting modules. Each M and F are the jumper connections between all of the lower modules including the bridge. I am suggesting a single cable with on end with 18inch leads with one male and one female Molex connector to attach to the buss connectors between and pair of outside modules.

**UPPER LEVEL**

No Buss wires. All tracks and accessory wiring should have at least 1 drop for all connections on each Upper module Wired together with 9 pin female Molex connection under the board and wired to the jumper cable to go to lower level jumper. The will attache to Modules L-2, L-4, L-6 and L-Bridge

# Button / Timer Control

All Wires are 12 gauge extension cords, BLACK in color. The **colors** are simply for tracing the wiring if there is a problem.

I want to install on the transformer cart all of the large Circuit Breaker and Collector timer boxes on a lower shelf of the Transformer Cart and the six (6) track transformers on a top shelf along with the on off switch (RED).

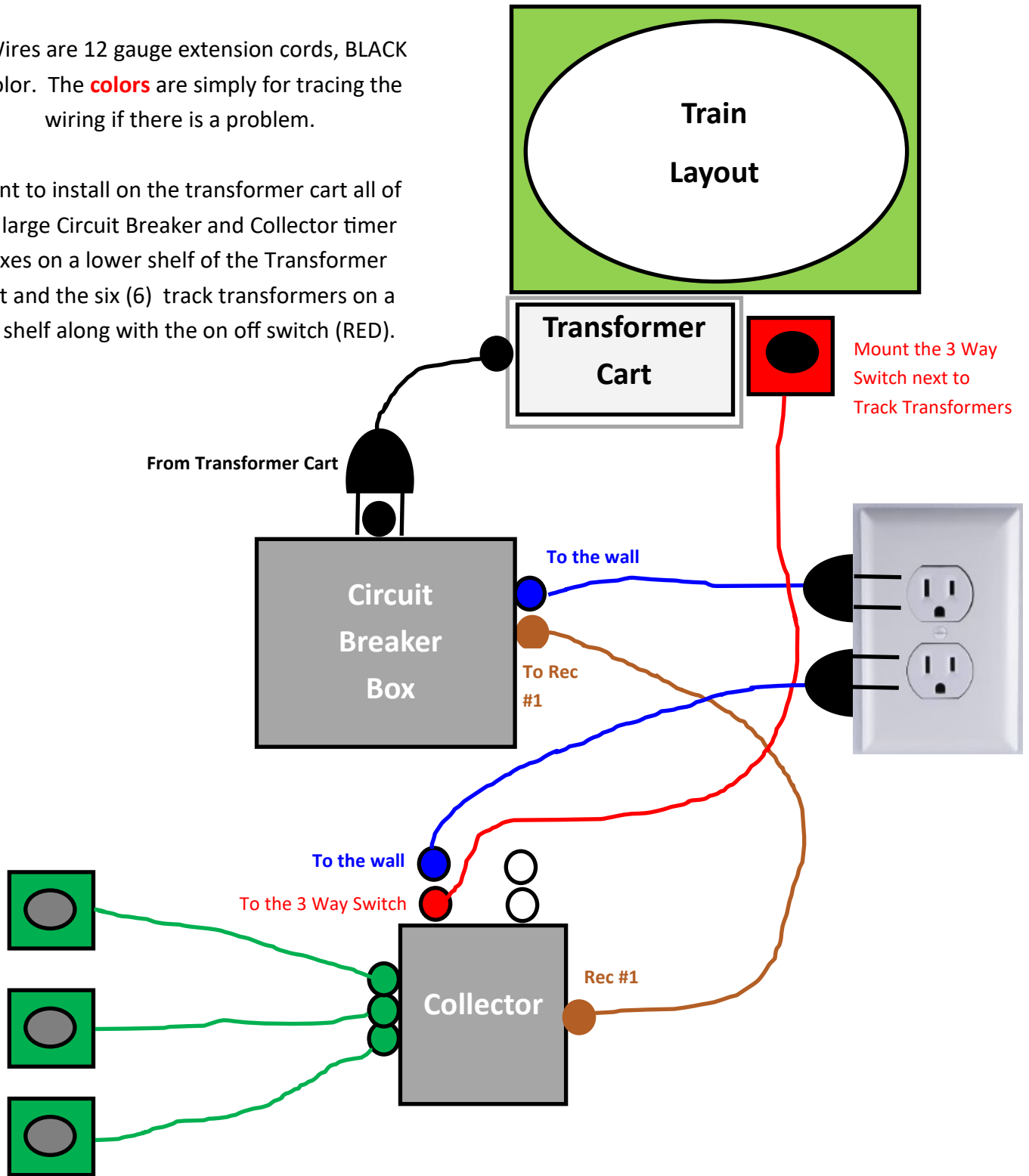

**3 PUSHBUTTONS ATTACH TO THE FRONT OF THE LAYOUT**

All Molex connections listed are from the power source

THE ONLY VOLTAGE USED AT THIS TIME IS 14 V AC FOR ALL ACCESSORIES

THERE ARE UP TO 3 ACCESSORY CIRCUITS USING ORANGE, PURPLE AND PINK.

VOLTAGE	MOLEX PINS	HOT / POS	COM / NEG	COLORS
---------	------------	-----------	-----------	--------

All train Tracks are AC Current

Up to three 12—14 V AC Accessory lines ORANGE PURPLE and maybe GREEN.

COMMON	ALTERNATING	WHITE	WHITE	WHITE
12 V AC	ACCESSORY #1	ORANGE	WHITE	ORANGE

## 12 Volt AC Male Housing



Currently this is the only Molex Accessory voltage listed on the layout. Note the Male Molex is mounted to the module and the Female is on the building leads.

White AC Common

Orange AC Hot

We are converting all bulbs as much as possible from 12 to 14 V AC to LEDs that will operate on 12 to 18 volt DC.

All Positive leads will be connected to the Orange accessory leads 12 V AC.

All negative leads will be connected to the White Accessory leads 12 V AC

# Hamilton City A - City Molex Plugs.pub

Visitors Viewing Outside of Module

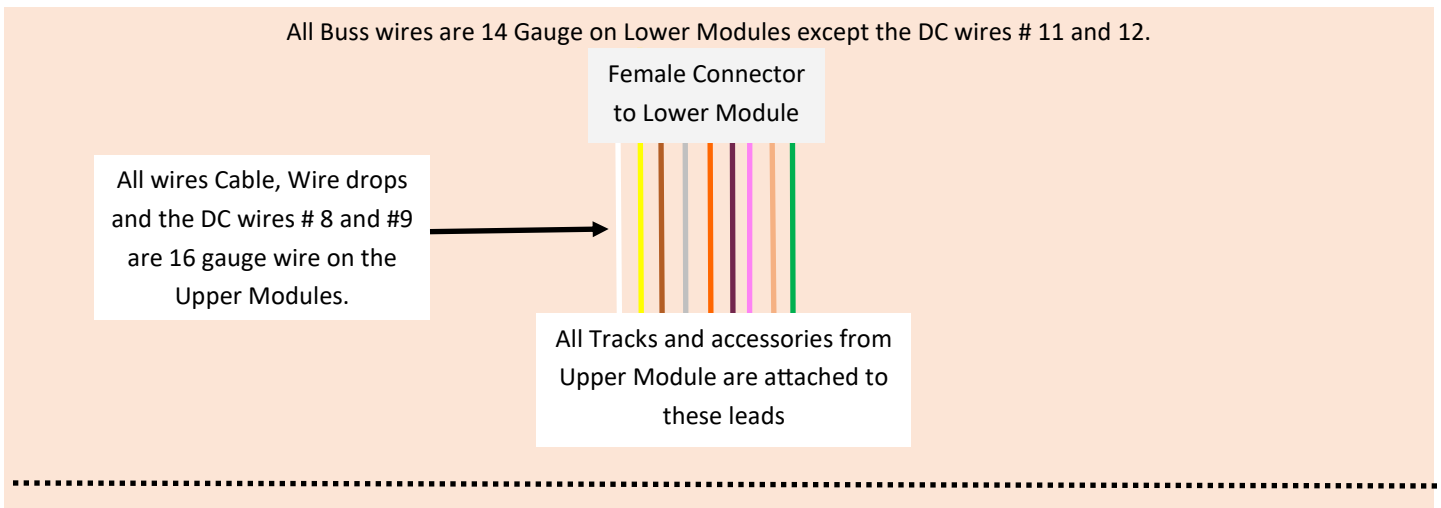
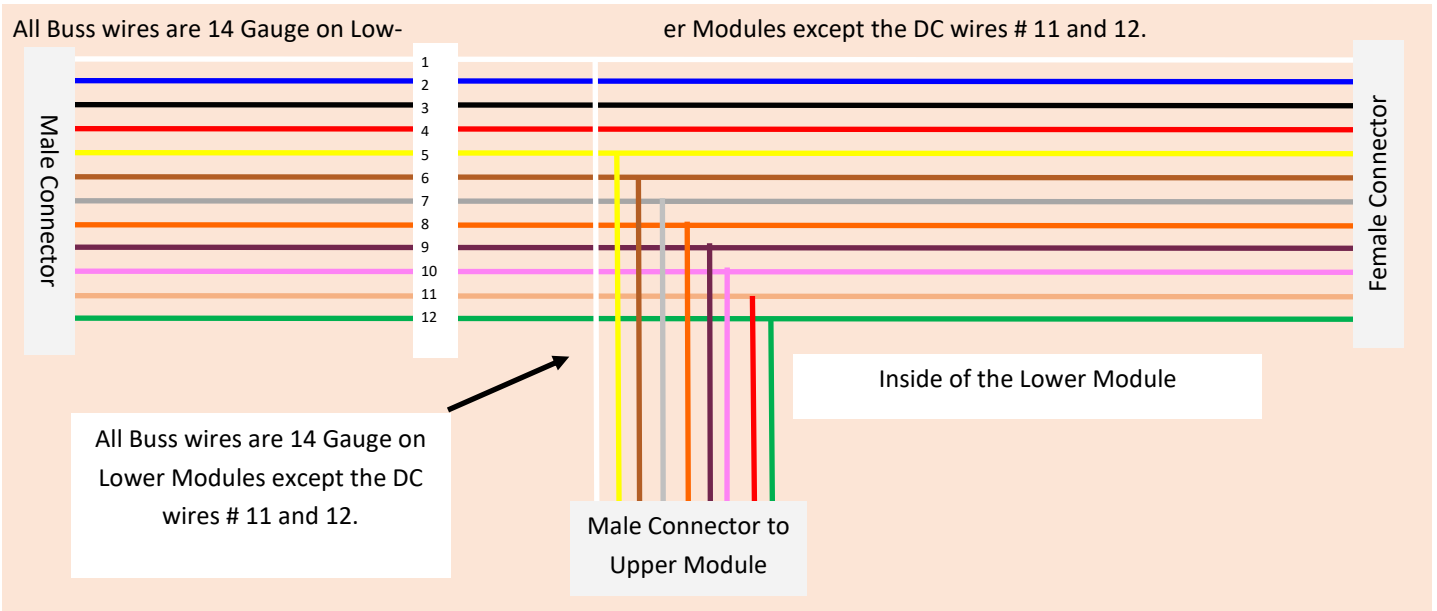

**Attach to Buss on lower module**  
**Attach to the Cable end on upper module**  
**Mound the Male Plug to the board**

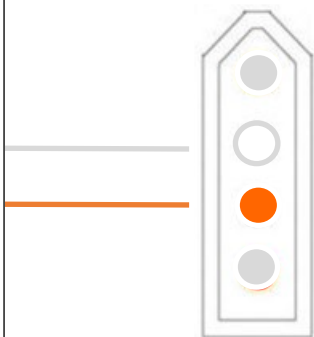

White AC Common  
Orange AC Hot

Use a female 4 pin plug attached to the accessory using the 2 middle pins White in #2 and Orange in #3. Plug into the

Update this page 26-05-22